

USER MANUAL for quadrature counter

type: **PAC-94ID**

firmware version: 4.02 or higher



Read the user's manual carefully before starting to use the unit.
Producer reserves the right to implement changes without prior notice.

CONTENTS

1. BASIC REQUIREMENTS AND USER SAFETY	3
2. GENERAL CHARACTERISTICS	4
3. TECHNICAL DATA	4
4. DEVICE INSTALLATION	6
4.1. UNPACKING	6
4.2. ASSEMBLY	6
4.3. CONNECTION METHOD	8
4.4. MAINTENANCE	13
5. FRONT PANEL DESCRIPTION	14
6. PRINCIPLE OF OPERATION	15
6.1. MEASUREMENT MODE	15
6.2. SELECTING OF DISPLAYED VALUE	17
6.3. CONTROL OF THE RELAY OUTPUTS.....	19
6.3.1. "Standard" mode (distance measurement)	20
6.3.2. "Marker" mode (marking of the distance)	22
7. DEVICE PROGRAMMING	24
7.1. PROGRAMMING MENU.....	24
7.2. PARAMETERS EDITION.....	25
7.2.1. Numeric parameters (digit change mode)	25
7.2.2. Numeric parameters (slide change mode).....	25
7.2.3. Switch parameters ("LIST" type)	25
7.3. MENU DESCRIPTION.....	26
7.3.1. "rELAy1" ÷ "rELAy4" menu.....	26
7.3.2. "mAin" menu.....	27
7.3.3. "rESEtS" menu	28
7.3.4. "Pr In" menu.....	30
7.3.5. "PrESCA" menu.....	31
7.3.6. "rS-485" menu	31
7.3.7. Menu "SECu".....	32
7.3.8. "briGHt" parameter.....	34
7.3.9. "Edit" parameter.....	34
7.3.10. "dEFS" parameter.....	34
7.4. MENU STRUCTURE	35
8. EXAMPLES OF PRESCALER PARAMETERS CALCULATION	37
9. THE MODBUS PROTOCOL HANDLING	38
9.1. LIST OF REGISTERS.....	38
9.2. TRANSMISSION ERRORS DESCRIPTION.....	43
9.3. EXAMPLES OF QUERY/ANSWER FRAMES	43
10. DEFAULT AND USER'S SETTINGS LIST	46

Explanation of symbols used in the manual:



- This symbol denotes especially important guidelines concerning the installation and operation of the device. Not complying with the guidelines denoted by this symbol may cause an accident, damage or equipment destruction.

IF THE DEVICE IS NOT USED ACCORDING TO THE MANUAL THE USER IS RESPONSIBLE FOR POSSIBLE DAMAGES.



- This symbol denotes especially important characteristics of the unit. Read any information regarding this symbol carefully

1. BASIC REQUIREMENTS AND USER SAFETY



- The manufacturer is not responsible for any damages caused by inappropriate installation, not maintaining the proper technical condition and using the unit against its destination.

- Installation should be conducted by qualified personnel. During installation all available safety requirements should be considered. The fitter is responsible for executing the installation according to this manual, local safety and EMC regulations.

- The unit must be properly set-up, according to the application. Incorrect configuration can cause defective operation, which can lead to unit damage or an accident.

- If in the case of a defect of unit operation there is a risk of a serious threat to the safety of people or property additional, independent systems and solutions to prevent such a threat must be used.

- The unit uses dangerous voltage that can cause a lethal accident. The unit must be switched off and disconnected from the power supply prior to starting installation of troubleshooting (in the case of malfunction).

- Neighbouring and mating equipment must meet the requirements of appropriate standards and regulations concerning safety and be equipped with adequate anti-overvoltage and anti-interference filters.

- Do not attempt to disassemble, repair or modify the unit yourself. The unit has no user serviceable parts. Units, in which a defect was stated must be disconnected and submitted for repairs at an authorized service centre.



- In order to minimize fire or electric shock hazard, the unit must be protected against atmospheric precipitation and excessive humidity.

- Do not use the unit in areas threatened with excessive shocks, vibrations, dust, humidity, corrosive gasses and oils.

- Do not use the unit in explosion hazard areas.



- Do not use the unit in areas with significant temperature variations, exposed to condensation or icing.
- Do not use the unit in areas exposed to direct sunlight.
- Make sure that the ambient temperature (e.g. inside the control box) does not exceed the recommended values. In such cases forced cooling of the unit must be considered (e.g. by using a ventilator).



The unit is designed for operation in an industrial environment and must not be used in a household environment or similar.

2. GENERAL CHARACTERISTICS

The counter type **PAC-94ID** is designed to cooperation with quadrature incremental encoders. Settable recalculation factors (multiplier, divider and offset) allow displaying of the result in desired units. It is possible to define four sets of recalculation coefficients mul-div-offset-point (it means profiles), these profiles make recalculation between units easier. Main counter range is limited from -99999 to 999999. Build-in totalizer is 12 digits long (-999999999999 to 999999999999).

The unit can control up to 4 external devices (motors, signalling devices) via build in relay outputs, every in one of two modes (NO and NC). Activation of particular output can be done after achieving of preset value (threshold) by the counter. Deactivation of the output can be done after selected time (0 to 99.9 seconds or minutes) or when counted value goes less than selected threshold related to particular output. The autoreset function allows zeroing of the counter by itself when it reaches the threshold, and build in cycles counter counts the number of autoresets. Manual zeroing of the counter causes storing of present value into internal "resets memory" and makes possibility of its viewing in future (maximum 5 last resets).

PAC-94ID is equipped in 2 programmable inputs which allows external reset of selected counter (or group of counters) or change of counting direction (regardless of quadrature signal phase).

All internal registers of the counter (including direct driving of relays) are available via RS-485 interface (with MODBUS RTU protocol). All inputs of the counter are separated.

3. TECHNICAL DATA

Power supply voltage (depending on version)	85... 230 ...260 V _{AC/DC} ; 50 ÷ 60 Hz or 19... 24 ...50 V _{DC} ; 16... 24 ...35 V _{AC}
External fuse (required)	T - type, max. 2 A
Power consumption	max. 4.5 VA @ 85 V ÷ 260 V _{AC/DC} max. 4.5 VA @ 16 V ÷ 35 V _{AC} max. 4.5 W @ 19 V ÷ 50 V _{DC}

Pulse inputs	
A and B input	quadrature, counting (terminal no. 18, 19)
IN1 input	first programmable input (terminal no. 16)
IN2 input	second programmable input (terminal no. 17)
COM	common terminal (terminal no. 20)
Input levels	
low level:	0 V ÷ 1 V
high level:	10 V ÷ 30 V (about 12 mA @ 24 V)
Input frequency	max. 250 kHz
Outputs	
relay:	4 NO, 1 A / 250 V _{AC} (cos φ = 1)
or OC-type:	4 30 mA / 30 V _{DC} / 100 mW
sensor power supply:	24 V +5 %, -10 % / max. 100 mA, stabilized
Measurement range	
main counter:	-99 999 ÷ 999 999, plus decimal point
cycles counter:	
“standard” mode	0 ÷ 999 999
“marker” mode	-99 999 ÷ 999 999, plus decimal point
totalizer counter:	-99 999 999 999 ÷ 999 999 999 999
Communication interface	RS-485, 8N1 and 8N2, Modbus RTU, not separated
Baud rate	1200 bit/sec ÷ 115200 bit/sec
Display	LED, 6 digit, 13 mm height, red
Data memory	non-volatile memory, EEPROM type
Protection level	IP 65 (from front, after using waterproof cover) IP 40 (from front) IP 20 (housing and connection clips)
Housing type	panel
Housing material	NORYL - GFN2S E1
Housing dimensions	96 x 48 x 100 mm
Panel cutout	90.5 x 43 mm
Assembly depth	102 mm
Panel thickness	max. 5 mm
Operating temperature	0 °C to +50 °C
Storage temperature	-10 °C to +70 °C
Humidity	5 to 90 % no condensation
Altitude	up to 2000 meters above sea level
Screws tightening max. torque	0.5 Nm
Max. connection leads diameter	2.5 mm ²
Safety requirements	according to: PN-EN 61010-1 installation category: II pollution degree: 2 voltage in relation to ground: 300 V _{AC}

insulation resistance: $>20\text{ M}\Omega$
insulation strength between power supply and
input/output terminal: 1 min. @ 2300 V
insulation strength between relays terminal:
1 min. @ 1350 V

EMC

according to: PN-EN 61326



This is a class A unit. In housing or a similar area it can cause radio frequency interference. In such cases the user can be requested to use appropriate preventive measures.

4. DEVICE INSTALLATION

The unit has been designed and manufactured in a way assuring a high level of user safety and resistance to interference occurring in a typical industrial environment. In order to take full advantage of these characteristics installation of the unit must be conducted correctly and according to the local regulations.



- Read the basic safety requirements on page 3 prior to starting the installation.
- Ensure that the power supply network voltage corresponds to the nominal voltage stated on the unit's identification label.
- The load must correspond to the requirements listed in the technical data.
- All installation works must be conducted with a disconnected power supply.
- Protecting the power supply clamps against unauthorized persons must be taken into consideration.

4.1. UNPACKING

After removing the unit from the protective packaging, check for transportation damage. Any transportation damage must be immediately reported to the carrier. Also, write down the unit serial number on the housing and report the damage to the manufacturer.

Attached with the unit please find:

- user's manual
- warranty
- assembly brackets - 2 pieces

4.2. ASSEMBLY



- The unit is designed for mounting indoor inside housings (control panel, switchboard) assuring appropriate protection against electric impulse waves. Metal housing must be connected to the grounding in a way complying with the governing regulations.
- Disconnect the power supply prior to starting assembly.
- Check the correctness of the performed connections prior to switching the unit on.



In order to assembly the unit, a 90.5 x 43 mm mounting hole (Figure 4.1) must be prepared. The thickness of the material of which the panel is made must not exceed 5 mm. When preparing the mounting hole take the grooves for catches located on both sides of the housing into consideration (Figure 4.1). Place the unit in the mounting hole inserting it from the front side of the panel, and then fix it using the brackets (Figure 4.2). The minimum distances between assembly holes' axes - due to the thermal and mechanical conditions of operation - are 115 mm x 67 mm (Figure 4.3).

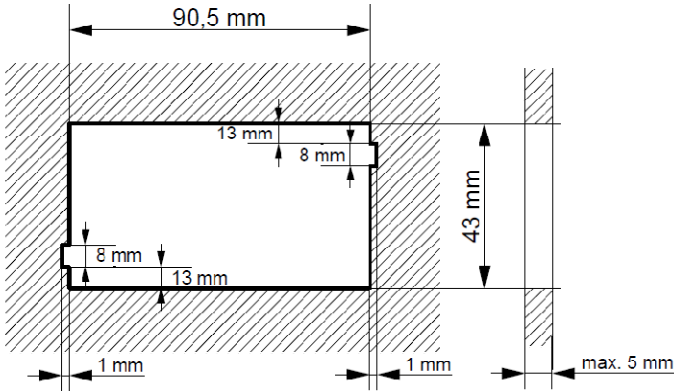

Figure 4.1. Mounting hole dimensions

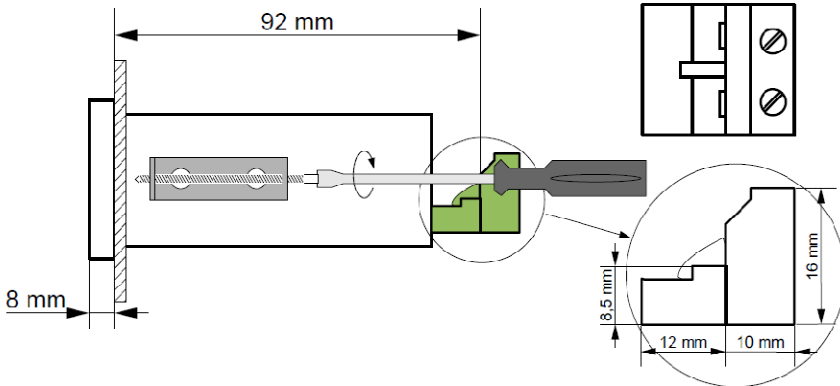

Figure 4.2. Installing of brackets, and dimensions of connectors.

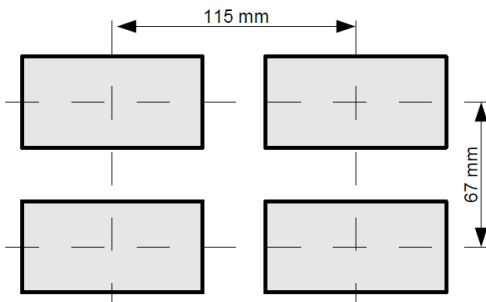

Figure 4.3. Minimum distances when assembly of a number of units

4.3. CONNECTION METHOD

Caution



- Installation should be conducted by qualified personnel. During installation all available safety requirements should be considered. The fitter is responsible for executing the installation according to this manual, local safety and EMC regulations.
- The unit is not equipped with an internal fuse or power supply circuit breaker. Because of this an external time-delay cut-out fuse with minimal possible nominal current value must be used (recommended bipolar, max. 2 A) and a power supply circuit-breaker located near the unit. In the case of using a monopolar fuse it must be mounted on the phase cable (L).
- The power supply network cable diameter must be selected in such a way that in the case of a short circuit of the cable from the side of the unit the cable shall be protected against destruction with an electrical installation fuse.
- Wiring must meet appropriate standards and local regulations and laws.
- In order to secure against accidental short circuit the connection cables must be terminated with appropriate insulated cable tips.
- Tighten the clamping screws. The recommended tightening torque is 0.5 Nm. Loose screws can cause fire or defective operation. Over tightening can lead to damaging the connections inside the units and breaking the thread.
- In the case of the unit being fitted with separable clamps they should be inserted into appropriate connectors in the unit, even if they are not used for any connections.
- **Unused clamps (marked as n.c.) must not be used for connecting any connecting cables (e.g. as bridges), because this can cause damage to the equipment or electric shock.**



- If the unit is equipped with housing, covers and sealing packing, protecting against water intrusion, pay special attention to their correct tightening or clamping. In the case of any doubt consider using additional preventive measures (covers, roofing, seals, etc.). Carelessly executed assembly can increase the risk of electric shock.
- After the installation is completed do not touch the unit's connections when it is switched on, because it carries the risk of electrical shock.

Due to possible significant interference in industrial installations appropriate measures assuring correct operation of the unit must be applied. To avoid the unit of improper indications keep recommendations listed below.

- Avoid common (parallel) leading of signal cables and transmission cables together with power supply cables and cables controlling induction loads (e.g. contactors). Such cables should cross at a right angle.
- Contactor coils and induction loads should be equipped with anti-interference protection systems, e.g. RC-type.
- Use of screened signal cables is recommended. Signal cable screens should be connected to the earthing only at one of the ends of the screened cable.
- In the case of magnetically induced interference the use of twisted couples of signal cables (so-called "spirals") is recommended. The spiral (best if shielded) must be used with RS-485 serial transmission connections.
- In the case of interference from the power supply side the use of appropriate anti-interference filters is recommended. Bear in mind that the connection between the filter and the unit should be as short as possible and the metal housing of the filter must be connected to the earthing with largest possible surface. The cables connected to the filter output must not run in parallel with cables with interference (e.g. circuits controlling relays or contactors).

Notes related to connection of encoders and control inputs:



Installation should be made accordingly to local law regulations, related to safety and electromagnetic compatibility. Essentially following recommendation should be preserved.

- use only shielded wires
- the shield should be connected to metal case of the encoder
- wires should be placed as close as possible to metal construction of the machine and as far as possible of interfering wires (e.g. supply of motors etc.)
- in case, while encoder is far off from the counter, and long wires must be used, it is recommended to use additional protection wire (bold enough) between counter's additional metal case and machine construction where encoder is mounted.

Connections of power supply voltage and measurement signals are executed using the screw connections on the back of the unit's housing (Figure 4.4 - 4.10).

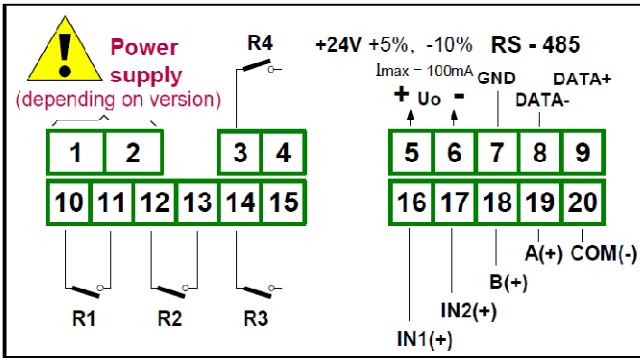

Figure 4.4. Terminals description (relay outputs)

Description of control signals' symbols.

- { IN1 } - first programmable input
- { IN2 } - second programmable input
- { A }, { B } - quadrature, counting
- { COM } - common terminal



All connections must be made while power supply is disconnected!

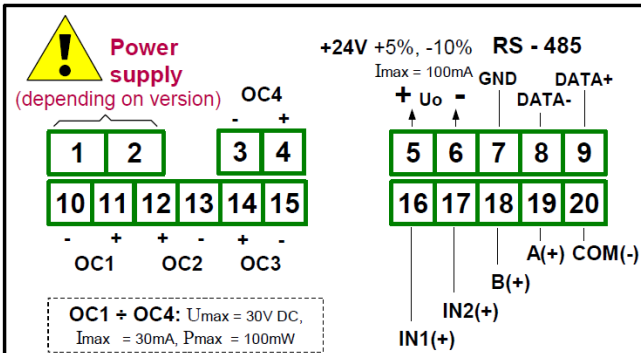

Figure 4.5. Terminals description (OC-type outputs)

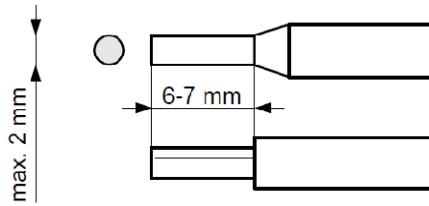

Figure 4.6. Method of cable insulation replacing and cable terminals

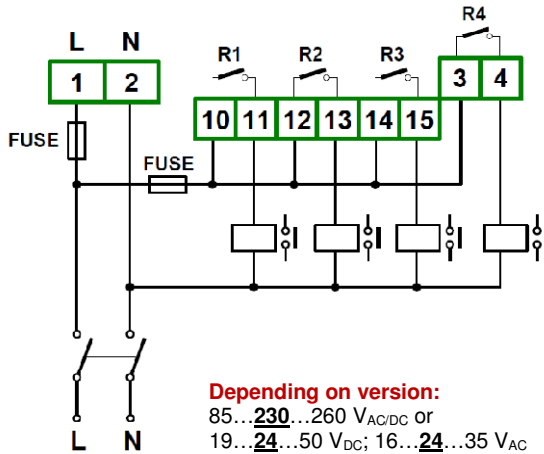

Figure 4.7. Connection of power supply and relays



Contacts of relay outputs are not equipped with spark suppressors. While use the relay outputs for switching of inductive loads (coils, contactors, power relays, electromagnets, motors etc.) it is required to use additional suppression circuit (typically capacitor 47 nF/ min. 250 V_{AC} in series with 100R/5 W resistor), connected in parallel to relay terminals or (better) directly on the load. In consequence of using the suppression circuit, the level of generated electromagnetic disturbances is lower, and the life of relay contacts rises.

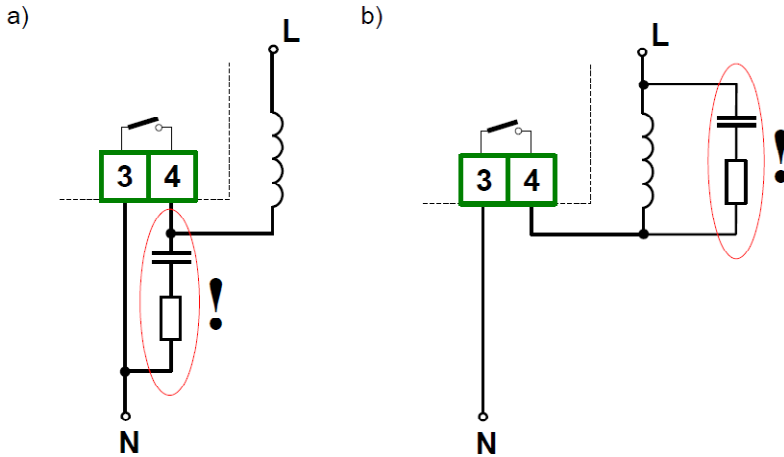

Figure 4.8. Examples of suppression circuit connection:
a) to relay terminals; b) to the inductive load

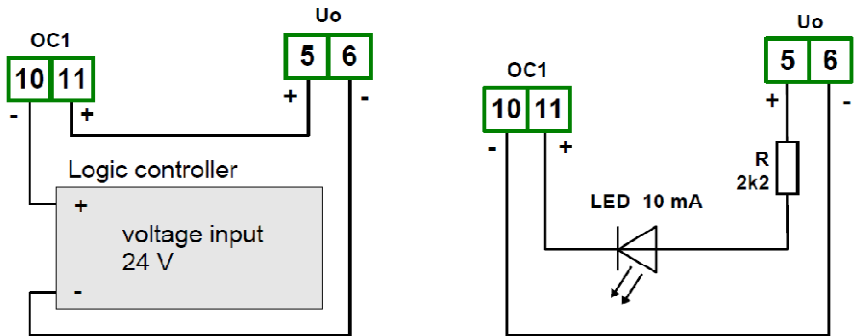

Figure 4.9. Example of OC-type outputs connection

Construction of the inputs allows connecting of encoders with common earth, common supply or push-pull type (Figure 4.10), without additional intermediary circuits.

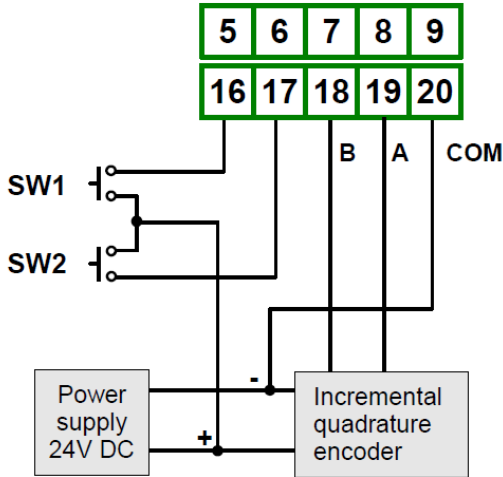

Figure 4.10. An example connection of incremental encoder.

4.4. MAINTENANCE

The unit does not have any internal replaceable or adjustable components available to the user. Pay attention to the ambient temperature in the room where the unit is operating. Excessively high temperatures cause faster ageing of the internal components and shorten the fault-free time of unit operation.

In cases where the unit gets dirty do not clean with solvents. For cleaning use warm water with small amount of detergent or in the case of more significant contamination ethyl or isopropyl alcohol.



Using any other agents can cause permanent damage to the housing.



Product marked with this symbol should not be placed in municipal waste. Please check local regulations for disposal and electronic products.

5. FRONT PANEL DESCRIPTION

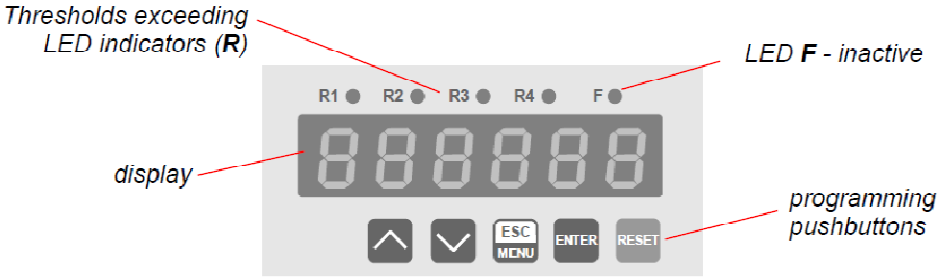

Symbols and functions of push-buttons:



Symbol used in the manual: **[ESC/MENU]**

Functions:

- Enter to main menu (press and hold by at least 2 sec.)
- Exit the current level and Enter to previous menu (or measure mode)
- Cancel the changes made in parameter being edited



Symbol used in the manual: **[ENTER]**

Functions:

- Start to edit the parameter
- Enter to the sub-menu
- Confirmation of changes made in parameter being edited



Symbol used in the manual: **[^]**

Functions:

- Change of the present menu
- Modification of the parameter value
- Change of display mode



Symbol used in the manual: **[v]**

Functions:

- Change of the present menu
- Modification of the parameter value
- Monitoring of current thresholds and “zeroing memory”
- Change of displayed half of the totalizer



Symbol used in the manual: **[RESET]**

Functions:

- zeroing the currently displayed counter, the zeroing must be confirmed by **[ENTER]** button.

6. PRINCIPLE OF OPERATION

After turning the power supply on, device ID and software version are showed on the display, next the data **stored while power supply off** is restored and device goes to the selected operation mode. The counter restores also displaying mode, it means shows counter which was displayed before power down.

6.1. MEASUREMENT MODE

In this state display shows current value of the **main counter**, **cycles counter** or **totalizer**. **Switching between counters can be done using [^] button.**

The type of currently presented counter is signalled by LED marked “F” (detailed informations in chapter **CHANGE OF DISPLAYED VALUE**).

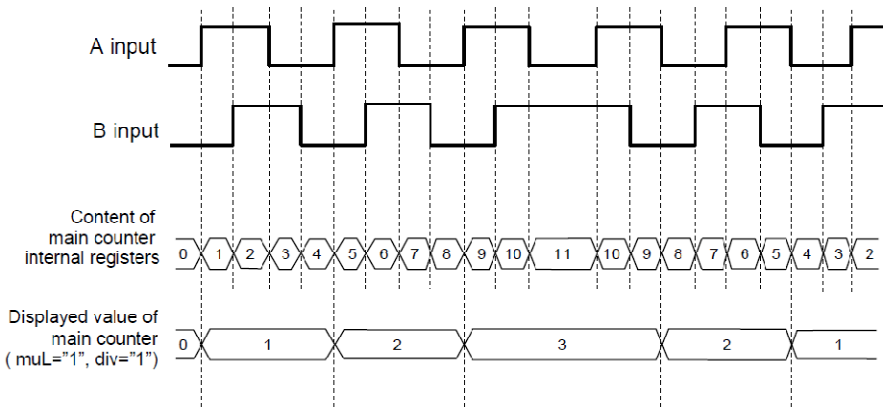

Figure 6.1. The counting principle of the PAC-94ID counters

In the standard counting mode, the device counts quadrature pulses “delivered” to counting inputs A and B (Figure 6.1), recalculates it by “**muL**” and “**div**” factors and finally shows the result on the display. Settable divider (**div**), multiplier (**muL**) and decimal point position (point) allow recalculation the pulses directly to desired units.

Impulses from A and B inputs are first delivered to internal register of main counter with resolution of 4 pulses on every quadrature cycle (pulse per edge), but displayed with resolution of quadrature cycles. To achieve better resolution (to half or quarter of cycle) parameter “**muL**” should be increased to 2 or 4 respectively. In addition all pulses counted by **main counter** are counted by **totalizer** too (with the same precision). The state (value) of **cycles counter** depends on current operation mode (see: **CONTROL OF THE RELAY OUTPUTS**).

If the result is out of **permissible counter range** (from “-99999” to “999999” for current value counter), special warning is displayed in place of the result. The warning type depends on the result and can be:

- “-Hi-” - if the result is higher than “999999”,
- “-Lo-” -if the result is lower than“-99999”,

When a given warning is displayed the counting of corresponding direction is inhibited, and the relays are opened.

The currently displayed counter (main counter, cycle counter or totalizer) can be zeroed at any time by:

- pressing of the [RESET] push-button and the confirmation of the [ENTER] button,
- activating the external programmable input {IN1} or {IN2} (if particular input has been programmed for zeroing of selected counter, see “Pr In” menu description),
- pre-sets of the internal registers via RS-485 interface

Zeroing of **main counter** with local keyboard causes storing of it's current value in internal FIFO register called “zeroing memory”. This register can store up to 5 values, and can be viewed at any time, using quick view mode.

Last state of main counter (before last zeroing) is available as “mEmo1”, and oldest stored value as “mEmo5”. Stored values **are not recalculated** after changing of prescaler sets. In **AUTORESET** mode counter do not stores it's values while automatic zeroing, and zeroing via programmable inputs as well.

In the measurement mode user can check values of main counter thresholds. After pressing [v] button, name of the threshold (e.g. “rELPr1”) and it's value will be displayed on the display in alternating mode. Successive pressings of the [v] button cause in displaying of successive thresholds and content of “zeroing memory register” (“mEmo1” ÷ “mEmo5”). If [v] will be pressed in 5 sec again, the next threshold or stored resets will be displayed, else the device comes back to the measurement mode. If a **free access** to the thresholds values is enabled (see: “SECu” menu), user can change the value of particular threshold pressing button [ENTER] (see: **PARAMETERS EDITION**).

All accessible parameters can be changed by entering the menu (see: **DEVICE PROGRAMMING**). Use the local keyboard or the remote controller to do it. (Note: all parameters can be remote changed via RS-485 interface).



Counting is independent of the operation mode of the counter. It is continued (in background) even in menu mode, but relays controlling and autoreset function are frozen for about 0.1 sec. while storing the parameters in menu mode.

6.2. SELECTING OF DISPLAYED VALUE

The **PAC-94ID** counter allows counting in three separate internal registers (counters). These registers are called: **main counter**, **cycles counter**, and **totalizer**. Selection of currently displayed counter (mode of displaying) can be done using [^] button, accordingly to the Figure 6.2.



Figure 6.2. Selection of displaying mode

LED lamp, marked “F” informs which one of the counter is being displayed at the moment. If **main counter** is displayed then LED “F” is turned off. If **cycles counter** is showed then LED is flashing, and if **totalizer** then LED lights constantly.

Due to **totalizer** can be 12 digits long, its value can be displayed in two separate parts. If its value is shorter than 6 digits then it is displayed like other counters, but if totalizer's value is longer than 6 digits, then the value is divided into less and more significant half. Less significant half is displayed by default, but if result is longer than 6 digits then most left decimal point flashes, informs that more significant part is available.

To change displayed half, press [v] button. When more significant half is showed on the display, it's most right decimal point flashes. Described situation is showed in Figure 6.3:

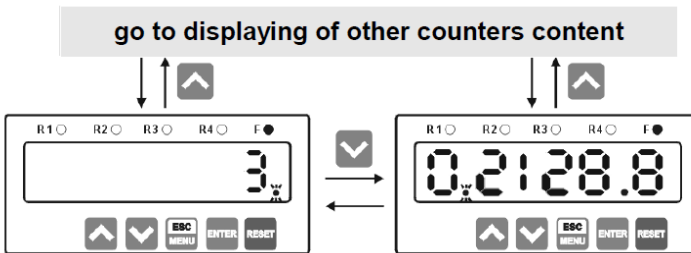

Figure 6.3. Selection between less and more significant half of the totalizer

In Figure 6.3 is showed situation, where totalizer value is equal to 302128.8. Most significant digit (3) must be displayed in more significant half, the rest of the digits can be displayed in less significant half. Because of totaliser's content must be displayed into two halves, zero on left side of less significant half is displayed, and most left decimal point flashes signalling that more significant half is available. Simultaneously right decimal point (between eights) lights constantly, indicating decimal point position.

To avoid situations when decimal point covers signalisation of more significant half, the range of decimal point position is limited to four digits (0.0000).

The **PAC-94ID** counter, can store which half of the **totalizer** is selected to be displayed. If more significant half is selected, and user goes to other counters values, then after switching to the **totalizer** again (using [^] button), more significant half will be displayed immediately. If less significant half is selected then counter goes to this half after next entering to the **totalizer**. After zeroing of the **totalizer**, less significant half is automatically selected, regardless of user selection, and more significant half will not be available until totalizer content will be longer than 6 digits. Figure 6.4 shows examples of switching between counters with selected less and more significant half of the totalizer. Additionally LED indicator is showed in the figure. **Main counter** value is "123.3"; **cycles counter** is "281"; and **totalizer** has 7 digits length value "312123.3".

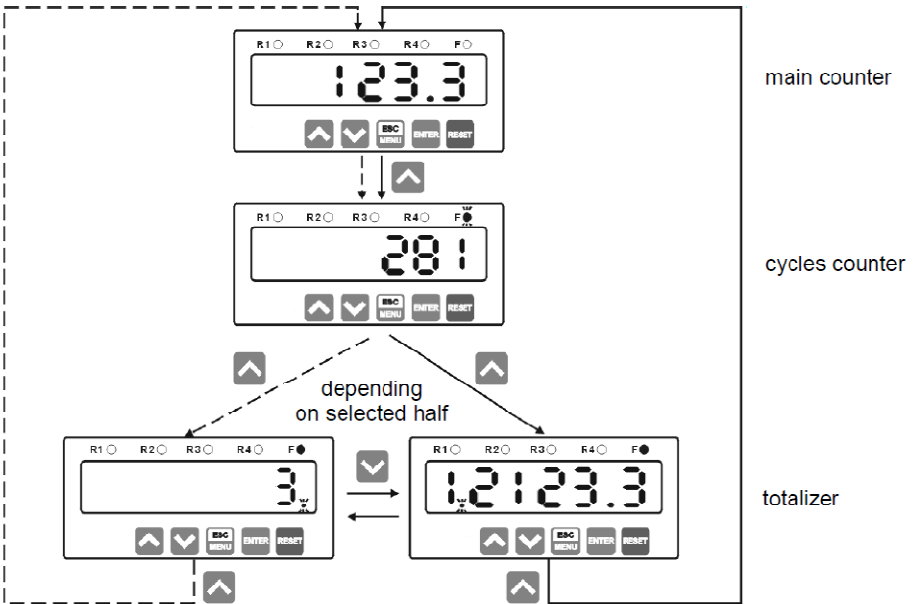

Figure 6.4. Examples of switching between counters

6.3. CONTROL OF THE RELAY OUTPUTS

The control of the object is realised due to **main counter** value, and/or **cycles counter** value, via relay outputs. Front panel LEDs named “R1” ÷ “R4” indicate the state of particular relay output.

Modes of the control can be changed depend on the values of parameters “SEtP”, “timE” and “modE”, and additional parameter “Src” for relays R3 and R4 . Relays R1 and R2 has its factory predefined control sources dependent on selected function of main counter (see parameter “Funct” in “mAin” menu).

Figure 6.5 presents the principle of relay outputs operation for example values of parameters. Parameter “SEtP” defines threshold of relay (trace: a). While normal operation of counter, relay output can change its state to **active only if** counter value reaches (or exceeds)the threshold (for “up” counting points A, C, E, G). The **active** state of the relay (close or open) is defined by parameter “modE”. Relays R3 and R4 can be controlled due to result of main counter or cycle counter. The selection of the source is being done using “Src” parameter in their menus.

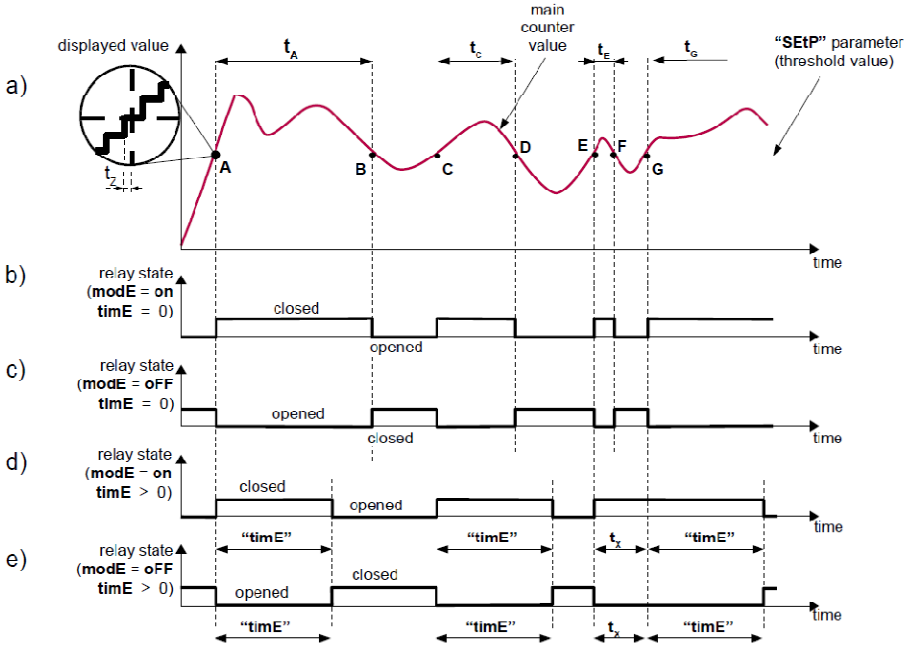

Description:

A, B, C, D, E, F, G

- time points where result exceeds thresholds value,

t_A, t_C, t_E, t_G

- time while counter keeps result at least equal to threshold value

t_x

- time between subsequent exceeds of threshold value (shorter than value of “timE” parameter)

t_z

- delay of relay reaction

Figure 6.5 Principle of relay outputs operation



The reaction of the counter on reaching of “threshold values” is not momentary, maximum delay in relay control (switch on or off of the relay) while output is being driven from main counter is less than 12 ms for outputs OC type, and 20 ms for electromechanical relays.

Parameter “**time**” defines how long relay stay **active** after its activation by counter value (after moment when counter has reached particular threshold).

- If parameter “**time**” is set to “**0**”, then relay stays in **active** state (periods: t_A , t_C , t_E , t_G) as long as counter value is equal or higher than **threshold value**. (traces: b, c). In case when periods t_A , t_C , t_E , t_G are shorter than delay of relay reaction (t_2 time), the relay can not change it's state to **active**.
- If parameter “**time**” is set to value different from “**0**”, then relay stay **active** during defined time regardless of counter value (traces: d, e). In case when period (t_x) between successive exceedings of threshold value (e.g. between points B and C) is shorter than period defined by parameter “**time**”, activation period of relay is prolonged by “**time**” (every time when counter value goes up and reaches threshold).



If parameter “**time**” = “**0**” and **AUTORESET** function is active, particular relay will not change it's state to **active**.
If alarm situation occurs, (e.g. counter value is greater than allowable **displaying range**) all relays are opened.

Parameter “**mode**” can be set to value “**modbus**”. In such case it is possible to drive relays via RS-485 interface. In this case relays are independent on counter value, “**time**” and “**SEtP**” settings, and change of it's state can be done exclusively via RS-485 interface, as presets of holding registers (see: **LIST OF REGISTERS**). While parameter “**mode**” is set to value “**on**” or “**oFF**”, presets of these registers do not causes any reaction, and reading of these registers show actual state of particular relays.



If “**modbus**” mode is active, than after power down and up relays are inactive.

All parameters corresponding to relay outputs are described in details in chapter “**rELAy1**” ÷ “**rELAy4**” menu

The counter **PAC-94ID** (it's relay outputs) can operate in one of two modes (“**standard**” mode or “**marker**” mode) selected via option “**Funct**” of “**mAin**” menu. Principle of operation of both “**standard**” and “**marker**” modes are described below.

6.3.1. “Standard” mode (distance measurement)

In this mode (Figure 6.6) settings available in menu “**rELAy1**” ÷ “**rELAy4**” are related directly to relays R1 ÷ R4. Relays' R1 and R2 thresholds are compared to **main counter** value, and relays' R3 and R4 thresholds are compared to source selected by **Src 3** and **Src 4** parameters respectively. Relays are driven due to the comparison's result. The value of the **main counter** is calculated accordingly to formula:

$$D_v = M_c \times \frac{\text{“mul”}}{\text{“div”}} \times \frac{1}{4} + \text{Offset}$$

where: D_v - displayed value
 M_c - content of main counter internal registers

Cycles counter displays current number of made autozeroings, and **totalizer** displays the sum of all pulses recalculated to desired units accordingly to formula:

$$B = L_t \times \frac{\text{"muL"}}{\text{"div"}} \times \frac{1}{4}$$

where: B - displayed value
L_t - content of totalizer internal registers

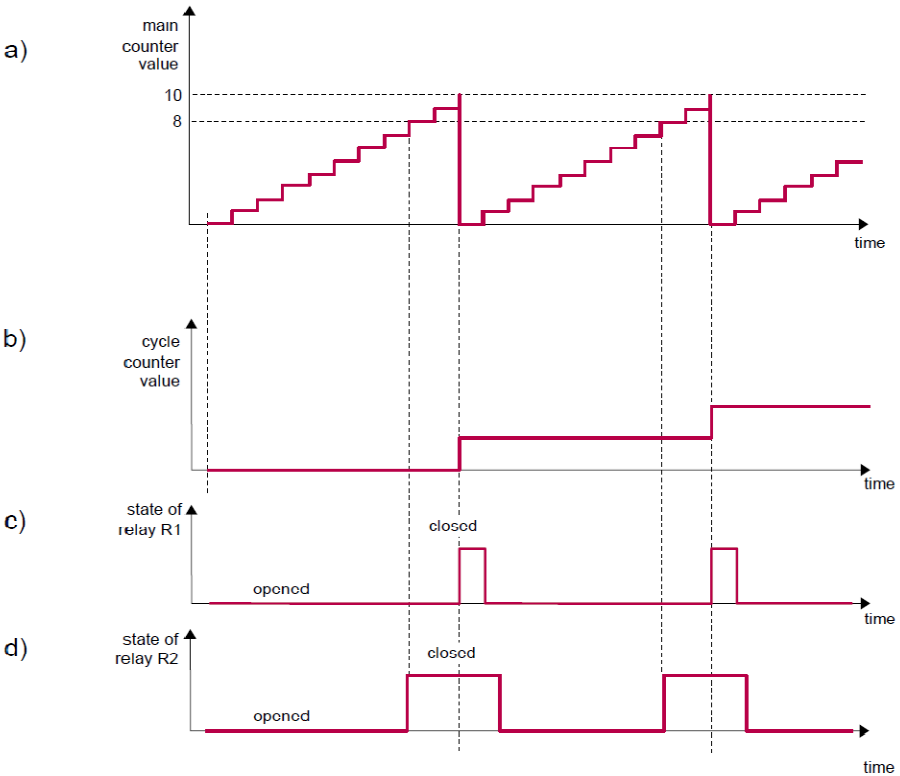

Figure 6.6 Example of relay controlling in „standard” mode;
settings: “SEtP 1”=10, “SEtP 2”=8, “ArESEt”=“on”, “tImE 1”>0, “tImE 2”>0

In “Std” mode It is possible to set **AUTORESET** function for “SEtP 1” threshold. This function enables automatic zeroing of the counter after, its value reaches relay R1 threshold (Figure 6.6, traces: a, c). If **AUTORESET** function is active, then relays R2 to R4 can be activated if their thresholds are not greater than relay R1 threshold (Figure 6.6, traces: a, d) or if R3 and R4 are being controlled by cycle counter.

6.3.2. “Marker” mode (marking of the distance)



For firmware version 4.02 or higher the functionality of Relays in MARKER mode has been changed.

This mode was designed especially to realize process of marking the segments of the same length. In this mode counter **PAC-94ID** can counts segments, and displays global length of the medium, and controls the cutter (e.g. marking segments of 10 m length, measure global length of the medium, and cuts 1000 m segments).

In this mode, all settings available in menu “**rELAY1**” are related to physical relay **R1** (marker), and this relay is driven due to value of the **main counter** (which displays distance between markers). Settings in menu “**rELAY2**” are related to physical relay **R2** (cutter), and this relay is controlled due to value displayed by **cycles counter** (which displays current global length of the medium). Settings in menus “**rELAY3**”, “**rELAY4**” control relays **R3**, **R4** respectively, due to the result of the selected source (depend on **Src 3** and **Src 4** parameters).

Principle of “marker mode” operation is presented in Figure 6.7.

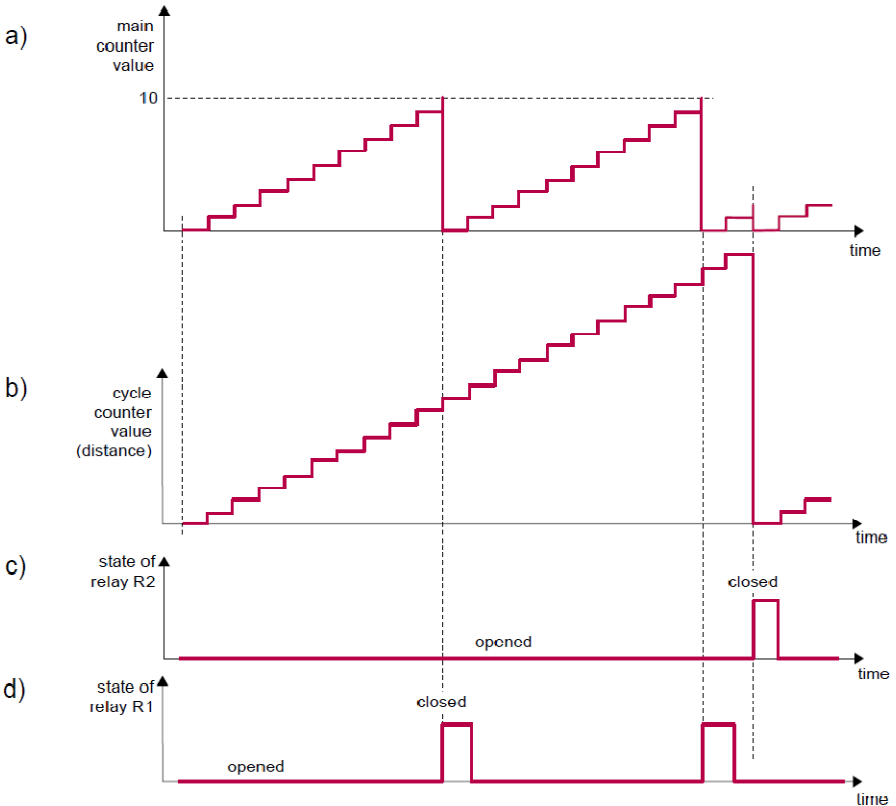

Figure 6.7 Example of relay controlling in „marker” mode;
 settings: “**SEtP 1**”=10, “**SEtP 2**”=22, “**ArESEt**”=“on”, “**time 1**”>0, “**time 2**”>0

Distance between markers (e.g 10 m) can be set via parameter “**SEtP 1**”, it mean relay R1 should drive marker (mechanical or printer; Figure 6.7, traces: a, d). The global length of the cut segments (e.g. 22 m, it needn't to be integer multiplicity of marked segments “**SEtP 1**”) user can set changing parameter “**SEtP 2**”, it mean relay R2 should drive the cutter.

In marker mode, **main counter** displays current distance between markers, and setting “**SEtP 1**” is compared to this value (Figure 6.7, traces: a, c). It's content is cleared when it reaches value equal “**SEtP 1**”, independently of parameter “**ArESEt**”. **Cycles counter** displays global distance since last cut (current length of the medium).

In marker mode **main counter** displays value calculated using the formula:

$$M_{DV} = M_c \times \frac{\text{"muL"}}{\text{"div"}} \times \frac{1}{4} + \text{Offset}$$

where: M_{DV} - displayed value (current distance since last marker)
 M_c - content of main counter's internal registers

Cycles counter displays global length of the medium as the result of the formula:

$$G_L = A_M \times \text{"SEtP 1"} + M_{DV}$$

where: G_L - displayed value (global length)
 A_M - number of markers (autozeroings of main counter)
 M_{DV} - current value of main counter (current distance since last marker)

If setting “**ArESEt**” = “**on**”, and **cycles counter** reach threshold defined by “**SEtP 2**”, then only content of **cycles counter will be zeroed** (Figure 6.7, traces: a, b), content of the **main counter** will be preserved. In case when it is necessary to clear the main counter too, then it is recommended to use programmable input with proper configuration.

If setting “**ArESEt**” = “**off**” and **cycles counter** reach threshold defined by “**SEtP 2**”, then **cycles counter** counts as before and relay “**rELAY2**” is controlled due to settings of parameters “**modE 2**” and “**timE 2**”.

It is strongly recommended to set threshold of R1 smaller than threshold of R2. In other case the autoreset of cycle counter may not behave in expected way (the cycle counter - distance will not be cleared, will be counting until main counter reaches R1 threshold, and displaying value equals to main counter value).

In marker mode **totalizer** displays the sum of all pulses recalculated to desired units accordingly to formula:

$$B = L_t \times \frac{\text{"muL"}}{\text{"div"}} \times \frac{1}{4}$$

where: B - displayed value
 L_t - content of totalizer internal registers

7. DEVICE PROGRAMMING

The device menu allow user to set all parameters connected to operation of measurement input, control modes, critical situations behaviour, communication via RS-485 and access settings. The meaning of the particular parameters is described in paragraph **MENU DESCRIPTION**.

Some of the parameters can be accessed without menu entering (quick view mode). After pressing **[v]** button, name of the threshold (e.g. “rELPr1”) and it’s value will be displayed on the display in alternating mode. Successive pressing of **[v]** button cause in displaying of registers “mEmo1” ÷ “mEmo5” content. If **[v]** will be pressed in 5 sec again, the next threshold or stored resets will be displayed, else the device comes back to the measurement mode. If a thresholds values **free access** is enabled (see: “**SECu**” menu), user can change the value of particular threshold pressing button **[ENTER]** (see: **PARAMETERS EDITION**). If free access to profile changes is set, (see **Menu “SECu”**), then user can change profile without knowing of main password.



If particular parameter has been changed and confirmed in quick view mode, its new value is displayed in alternating mode with parameter name by few seconds. User can check confirmed changes or switch viewed parameter pressing **[v]** button.

7.1. PROGRAMMING MENU

To enter main menu (being in the measurement mode) operator must to press and hold at least 2 sec. **[ESC/MENU]** button. If the user password is defined (see parameter “SEtCod“, menu “**SECu**”), operator have to enter correct one before proceeding to menu options. Entering of the passwords is similar to the edition of numeric parameters (see: **PARAMETERS EDITION**), however presently editing digit is showed only on the display, other digits are replaced by “_” sign.

After entering of last digit of the password first menu position will be displayed (if the password is correct) or warning “**Error**” in other case.



Pay attention when device parameters are being changed. If it is possible, turn off controlled installation (machine).

Functions of the buttons while sub-menu and parameters choice:



Selection of sub-menu or parameter for editing. Name of selected item (sub-menu or parameter) is displayed.



Operation of **[ENTER]** button depend on present menu position:

- if the name of some sub-menu is displayed - enter this sub-menu; name of the first parameter (or next level sub-menu) is displayed
- if the name of some parameter is displayed - enter the edition of this parameter; present value of the parameter is displayed



[ESC/MENU] button allow user to exit present menu level and goes to upper level menu (or measurement mode).



After about 1 min. since last use of the buttons, device exits the menu mode and returns to the measurement mode (only if no parameters are in editing mode).

7.2. PARAMETERS EDITION

To start edition of any parameter user should select name of desired one using [^] [v] buttons and then press [ENTER].

7.2.1. Numeric parameters (digit change mode)

Numerical parameters are displayed as decimal numbers. The mode of its new value entering depends on chosen edit method (see parameter “Edit”).

In mode “by digit” (“Edit”=“dig”) pressing one of the keys [^] or [v] causes change of current position (flashing digit) or the sign (+/-). Short pressing of the [ENTER] button causes change of the position (digit).

Press [ENTER] at least 2 seconds to accept the changes, after that question “Set?” is displayed, and user must to confirm (or cancel) the changes. To conform changes (and store it in EEPROM) press [ENTER] button shortly after “Set?” is displayed. To cancel the changes press [ESC] button shortly after “Set?” is displayed. After that device returns to the menu.

7.2.2. Numeric parameters (slide change mode)

In “slide change” mode (“Edit”=“Slid”), buttons [^] and [v] has different functions.

To increase edited value press (or press and hold) [^] button only, the increasing became quickest as long as button [^] is pressed. To slow down the increasing, button [v] can be used. If [v] is pressed shortly (and button [^] is still pressed), increasing slow down for a moment only, if [v] is pressed and held while button [^] is still pressed the increasing slow down and will be kept on lower speed.

To decrease edited value press (or press and hold) [v] button only. The decreasing became quickest as long as button [v] is pressed. To slow down the decreasing, button [^] can be used. If [^] is pressed shortly (and button [v] is still pressed), decreasing slow down for a moment only, if [^] is pressed and held while button [v] is still pressed the decreasing slow down and will be kept on lower speed.

Press [ENTER] at least 2 seconds to accept the changes, after that question “Set?” is displayed, and user must to confirm (or cancel) the changes. To conform changes (and store it in EEPROM) press [ENTER] button shortly after “Set?” is displayed. To cancel the changes press [ESC] button shortly after “Set?” is displayed. After that device returns to the menu.

7.2.3. Switch parameters (“LIST” type)

Switch parameters can be described as a sets of values (a lists) out of which only one of the options available on the list can be selected for the given parameter. Options of switching parameter are selected using [^], [v] keys.

Short pressing of [ENTER] causes in displaying of the acknowledge question (“Set?”). If key [ENTER] is pressed again, the changes are accepted, stored in EEPROM end the edition process finished. Pressing the key [ESC] after “Set?” causes in cancelling of made changes and returning to menu.

Functions of buttons when editing numeric and switching parameters:



While editing numeric parameter:

- change of current (flashing) digit
- slide change of value (acceleration, deceleration, direction change)

While editing switch parameter - selection of switch parameter.



If numerical parameter is being edited, a short press of **[ENTER]** button change edited position. A long press of **[ENTER]** button (at least 2 sec.) causes of display a “**SEt?**” ask, which allow user to make sure if change of the parameter value is correct. If switch parameter is being edited, a short press of **[ENTER]** button causes of display a “**SEt?**” ask. When **[ENTER]** button is pressed again (while “**SEt?**” is displayed) the new value of the parameter is stored in EEPROM memory.



Pressing this button operator can cancel the changes done up to now (if they were not approved by **[ENTER]** button after the “**SEt?**” ask) and come back to menu

7.3. MENU DESCRIPTION

“**Cd 0 - - -**”

Password checking. If password is set different from “**0000**”, than every enter to main menu follows the entering of password. If entered password is correct first menu position else warning “**Error**” will be displayed, and unit returns to measurement mode.



Due to problem with direct displaying of “**m**” letter, it is exchanged with special signs “**ñ**”. Independently in user manual letters “**m**” is used to make it more readable (example: “**modE**”).

7.3.1. “**rELAy1**” ÷ “**rELAy4**” menu

This menu allows to configure the operation mode of relays and LEDs marked “**R**” (e.g. “**R1**”). If there are few relay outputs available, then every output has its own configuration menu (e.g. menu “**rELAy2**” for relay (LED) “**R2**”). Principle of the relays operation is described in paragraph **CONTROL OF THE RELAY OUTPUTS**.

“**Src3**”, “**Src4**” - these parameters are available in “**rELAy3**”, “**rELAy4**” menus only, and allow selection of counter for driving of the relay. Relays R3 and R4 are fully configurable in all operation modes of the counter. User can select the counter due to which value the relay will be driven. Possibilities:

“**main**” - control of the relay due to value of main counter

“**CyCLES**” - control of the relay due to value of cycle counter / distance counter (in “marker” mode)

“SEtP 1” ÷
“SEtP 4” - threshold of the relay (range -99999 ÷ 999999). Negative values can be input by selecting a “-” sign on first digit (to change value use [^] and [v] buttons).

“modE1” ÷
“modE4” - relay operation mode, this parameters define the **active state** of the relay, it means state of relay while the counter reaches **threshold value**, at “up counting”, available modes:

“noAct” - the relay is not active (permanent turned off)

“on” - the relay is turned on (closed) when result reaches **threshold value**

“oFF” - the relay is turned off (opened) when result reaches **threshold value**

“modbuS” - the relay is controlled via RS-485 interface, independently on the counter result and parameters “SEtP” and “tImE”



- When a particular LED lights, its mean the relay is closed
- If parameter “modE” is set to “modbuS” value, after power supply off and on again, relays are open

“timE1” ÷
“timE4” - the time period of the relay **active state**. Can be set to values from “0.1” to “99.9”, and express the time in seconds or minutes (depending on “unit” parameter). If this parameter is set to value different from “0.0” the relay is **active** independently of the result (even if the counter is zeroed). If this parameter is set to “0.0” the relay stays **active** as long as the result is same or higher of the particular **threshold value**.



While parameter “tImE 1” = “0” and **AUTORESET** is active, relay R1 will not change its state to **active**, or due to delays will be activated for very short period of time. If user wants not use R1 it is recommended to set “modE 1” = “noAct”.

“unit 1” ÷ “unit 4”- unit of time for “tImE” parameter. Can be set on one of two values:

“min” - minutes,

“SEC” - seconds.

7.3.2. “mAin” menu

This menu contains settings of **main counter**, and device operation mode.

“Funct” - This parameter allows to define operation mode of the relay outputs. Principle of the relays operation is described in paragraph **CONTROL OF THE RELAY OUTPUTS**. Parameter can be set to one of the values:

“std” - standard mode. Menu “rELAy1” ÷ “rELAy4” are related to relays R1 ÷ R4 respectively, and their thresholds are compared to result of the **main counter**

“mAr” - marker mode. Menu **“rELAY1”** is related to physical relay R1 (marker), and controls it due to the result of the **main counter** (current position between two markers). Menu **“rELAY2”** is related to physical relay R2 and controls it due to the content of the **cycles counter** (global length of the medium). Menus **“rELAY3”**, **“rELAY4”** control relays R3 and R4 respectively, due to the result of the selected source (depend on **Src 3** and **Src 4** parameters).

“dir” - this parameter defines the direction of counting:

“norm” - direction equal as phase of quadrature cycle on A -B inputs
“rEv” - direction opposite to phase of quadrature cycle on A -B inputs



After change of direction, the “jump” of counting can occur, therefore it is recommended to clear all counters before direction change.

7.3.3. “rESEtS” menu

This menu contains parameters defining the resets modes of all counters.

“ArESET” - this parameter enables the auto zeroing mode (**AUTORESET** function). In **“standard”** mode **AUTORESET** clears **main counter** when it reaches the value equal to **“SEtP 1”**. The cycle counter has no autoreset function in this mode.
 In **“marker”** mode **AUTORESET** corresponds to **cycles counter**, and clears it when its value reaches **“SEtP 2”**. In this mode **AUTORESET** of **main counter** is permanently enabled. This parameter can be set to:

“on” - **AUTORESET** function is active
“oFF” - **AUTORESET** function is inactive

“rES m” - defines enabled sources of **main counter** zeroing. Available options:

“mAn” - manual reset only. This value enables only manual reset, which can be done by pressing the **[RESET]** button on the front panel. This operation must to be approved by **[ENTER]** button.

“EL” - it enables the clearing of the counter by external electrical signal, feeded to selected (and properly configured) programmable input (see **Menu “Pr In”**). When an active state is delivered on selected programmable input, the clearing of the counter happens. The active state must be longer than 1 ms. In this mode manual clearing of the counter is unavailable.

“ALL” - this option enables both manual (using **[RESET]** button) and electronic reset.

“nonE” - this option disables both manual and electronic reset.



Zeroing of the totalizer can be done via RS-485 interface by presets of some registers with value 0000h. Remote zeroing is available in “**ALL**”, “**EL**” and “**mAn**” modes too.

“**rES c**”

- defines enabled sources of **cycles counter** zeroing. Available options:

“**mAn**”

- manual reset only. This value enables only manual reset, which can be done by pressing the [**RESET**] button on the front panel. This operation must to be approved by [**ENTER**] button.

“**EL**”

- it enables the clearing of the counter by external electrical signal, feeded to selected (and properly configured) programmable input (see **Menu „Pr In**”). When an active state is delivered on selected programmable input, the clearing of the counter happens. The active state must be longer than 1 ms. In this mode manual clearing of the counter is unavailable.

“**ALL**”

- this option enables both manual (using [**RESET**] button) and electronic reset.

“**nonE**”

- this option disables both manual and electronic reset.



Zeroing of the totalizer can be done via RS-485 interface by presets of some registers with value 0000h. Remote zeroing is available in “**ALL**”, “**EL**” and “**mAn**” modes too.

“**rES t**”

- defines enabled sources of **totalizer** zeroing. Available options:

“**mAn**”

- manual reset only. This value enables only manual reset, which can be done by pressing the [**RESET**] button on the front panel. This operation must to be approved by [**ENTER**] button.

“**EL**”

- it enables the clearing of the counter by external electrical signal, feeded to selected (and properly configured) programmable input (see **Menu “Pr In**”). When an active state is delivered on selected programmable input, the clearing of the counter happens. The active state must be longer than 1 ms. In this mode manual clearing of the counter is unavailable.

“**ALL**”

- this option enables both manual (using [**RESET**] button) and electronic reset.

“**nonE**”

- this option disables both manual and electronic reset.



Zeroing of the totalizer can be done via RS-485 interface by presets of some registers with value 0000h. Remote zeroing is available in “**ALL**”, “**EL**” and “**mAn**” modes too.

7.3.4. "Pr In" menu

This parameter defines the function of the programmable inputs.

"In 1", "In 2" - defines the function of the programmable inputs { IN1 }, { IN2 } respectively.

Available functions:

- "diSAbL" - input inactive
- "rES m" - **main counter** zeroing
- "rES c" - **cycles counter** zeroing
- "rES mc" - both **main counter** and **cycles counter** zeroing
- "rES t" - **totalizer** zeroing
- "rES mt" - both **main counter** and **totalizer** zeroing
- "rES ct" - both **cycles counter** and **totalizer** zeroing
- "rES ALL" - all counters zeroing
- "dirEct" - change of counting direction (regardless of quadrature cycle phase)



To allow particular input to clear selected counter (or group of counters) the electrical clearing of this counter (or group) must be enabled (see menu "rESEtS").

Actual direction of counting is ex-or sum of programmable inputs states (inputs being in "dirEct" mode) and parameter "dir" of "main" menu.

All possibilities of direction change are presented in table below:

"In1" parameter	"In2" parameter	"dir" parameter	Counting direction (agree or oposite to phase of quadrature cycle on A-B inputs)
dirEct	dirEct	norm	agree while states of inputs {IN1}={IN2} opposite while states of inputs {IN1}≠{IN2}
dirEct	dirEct	rev	opposite while states of inputs {IN1}={IN2} agree while states of inputs {IN1}≠{IN2}
dirEct	<i>other</i>	norm	agree while state of input {IN1} is active opposite while state of input {IN1} is inactive
dirEct	<i>other</i>	rev	opposite while state of input {IN1} is active agree while state of input {IN1} is inactive
<i>other</i>	dirEct	norm	agree while state of input {IN2} is active opposite while state of input {IN2} is inactive
<i>other</i>	dirEct	rev	opposite while state of input {IN2} is active agree while state of input {IN2} is inactive
<i>other</i>	<i>other</i>	norm	Selected by "dir" parameter
<i>other</i>	<i>other</i>	rev	

Tab.7.1. Possibilities of direction changes

7.3.5. "PrESCA" menu

This menu contains parameter which configure the prescalling parameters (recalculations of counted pulses). This menu allows the user to set individual prescalers, and to scale the counter in desired units. Available options:

- "ProFiL" - selection of the current profile. Profile is the set of the "muL", "div", "oFFSEt" and "Point" factors. It allows quick change of these parameters, what can be useful to change the units. There are available 4 user profiles, and presently available "muL", "div", "oFFSEt" and "Point", are related to present profile. To change values of parameters related with other profile, first selection of desired profile must be done.
- "muL" - multiply coefficient , range -99999 to 999999, (the multiplier of the current profile can be changed only)
- "div" - divide coefficient, range 1 do 999999, this parameter defines the internal modulo counter, (the divider of the current profile can be changed only)
- "oFFSEt" - offset coefficient, range: -99999 do 999999 (the offset of the current profile can be changed only)
- "Point" - decimal point position



- "div" parameter can't be set to "000000", entered value is controlled by firmware.
- "muL", "div", "oFFSEt" and "Point" factors for different profiles can be made after selection of desired profile.
- Firmware uses fixed point arithmetic (with rounding down).

7.3.6. "rS-485" menu

This menu is connected with RS-485 interface, and sets his properties:

- "Addr" - this parameter defines the address of the device, accordingly to Modbus protocol. It can be set in range from 0 to 199. If the value 0 is set then device, responds to frames with address 255 (FFh).
- "bAud" - this parameter determines RS-485 interface baud rate. It can be set to one of 8 possible values: "1.2", "2.4", "4.8", "9.6", "19.2", "38.4", "57.6", "115.2", which respond to the baud rates of 1200, 2400, 4800, 9600, 19200, 38400, 57600 and 115200 bit/sec respectively.
- "mbAccE" - this parameter sets the access to the configuration registers of the device. Possible values:
 - "on" - configuration registers can be set via RS-485 interface,
 - "oFF" - configuration registers can not be set via RS-485 interface.



The access to registers no 05h ÷ 0Eh cannot be denied by "mbAccE" parameter (see: **LIST OF REGISTERS**).

“mbtime” - this parameter defines maximal time (sec) between following frames received by the device. Parameter **“mbtime”** can be set to values from 0 to 99 seconds. The value 0 means that the time will be not controlled.

“rESP” - this parameter defines minimal (additional) delay between the Modbus message and the answer of the device (received and sent via RS-485 interface). This additional delay allows the device to work with poor RS-converters which do not works properly on baud rates higher than 19200. This parameter can be set to one of values:

- “Std”** - answer as quick as possible, no additional delay
- “10c”**
- “20c”** } - answer delayed of 10, 20, 50, 100 of 200 chars respectively,
- “50c”** } where one character time depends on selected baud rate
- “100c”**
- “200c”**



In the most cases parameter **“rESP”** should be set to **“Std”** (no additional delay). Unfortunately for some third party RS-converters **“rESP”** should be adjusted experimentally. Table 7.2 contains most frequently used values.

“bAud” parameter	“38.4”	“57.6”	“115.2”
“rESP” parameter	“ 10c”	“ 20c”	“ 50c”

Tab.7.2. Settings of “rESP” parameter

7.3.7. Menu “SECu”

This menu contains presets connected with availability of other parameters:

“SEtCod” - user password (4-digits number). If this parameter is set at value **“0000”**, user password is turned off.

If the user do not remember his password, the access to the menu is possible by the “one-use password”. To get this password please contact with Marketing Division. “Single use password” can be used only one time, after that it is destroyed. Entering this password causes in clearing of user password, it means sets the user password to “0000”.



The “one-use password” can be used **ONE TIME ONLY**, it is impossible to use it again! The “one-use password” can be restored by Service Division only.

“A rEL1” ÷
“A rEL4”

- this options permits user (“on”) or prohibits (“oFF”) to modify the thresholds of the relays/LEDs R1 ÷ R4 without knowledge about user password. The functionality of quick view mode is showed in Figure 7.1.

“A ProF”

- this options permits user (“on”) or prohibits (“oFF”) to change of active profile without knowledge about user password.

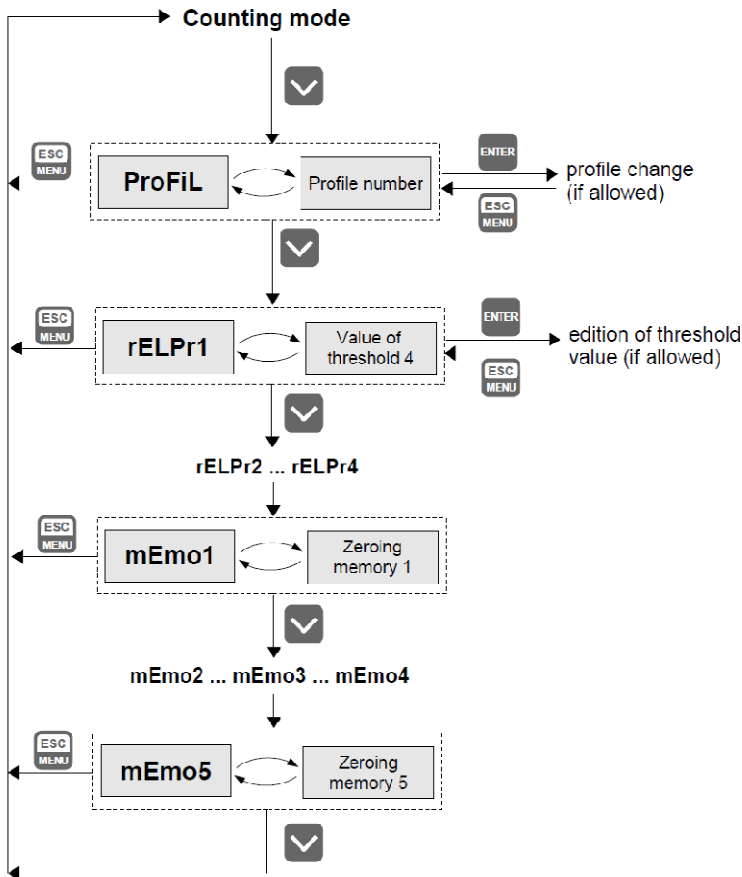

Figure 7.1 Functionality of quick view mode

7.3.8. “briGHt” parameter

This parameter allows user to set bright of the LED display, bright can be set to conventional values from 1 to 8.

7.3.9. “Edit” parameter

This parameter allows to change the edition mode of numerical parameters:

- “dig” - the change to “by digit” mode
- “Slid” - slide change mode

7.3.10. “dEFS” parameter

This setting allows to restore the factory settings of the device. To get the access to this option special password is required: “5465”, next the device displays acknowledge question “SEt?”. Press [ENTER] to acknowledge the restoring of factory settings or [ESC] to cancel.

7.4. MENU STRUCTURE

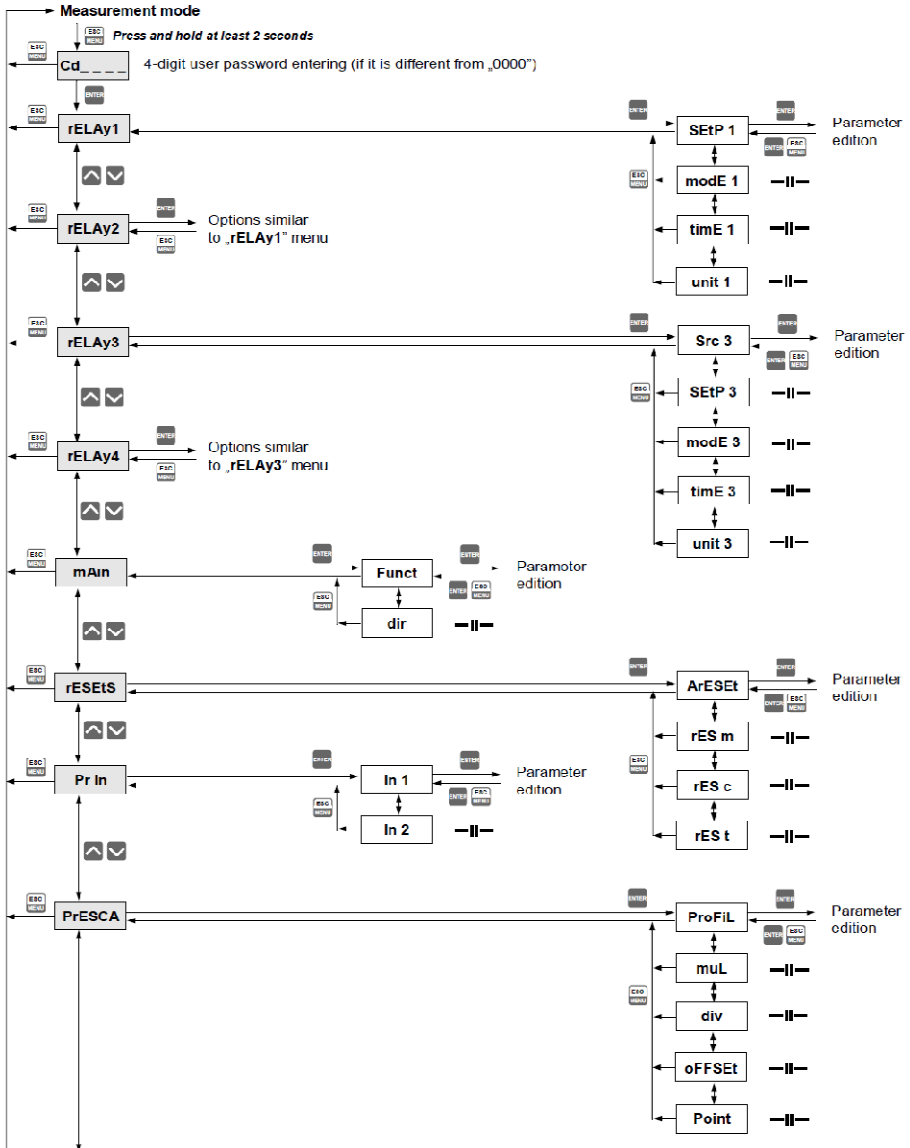

See next page

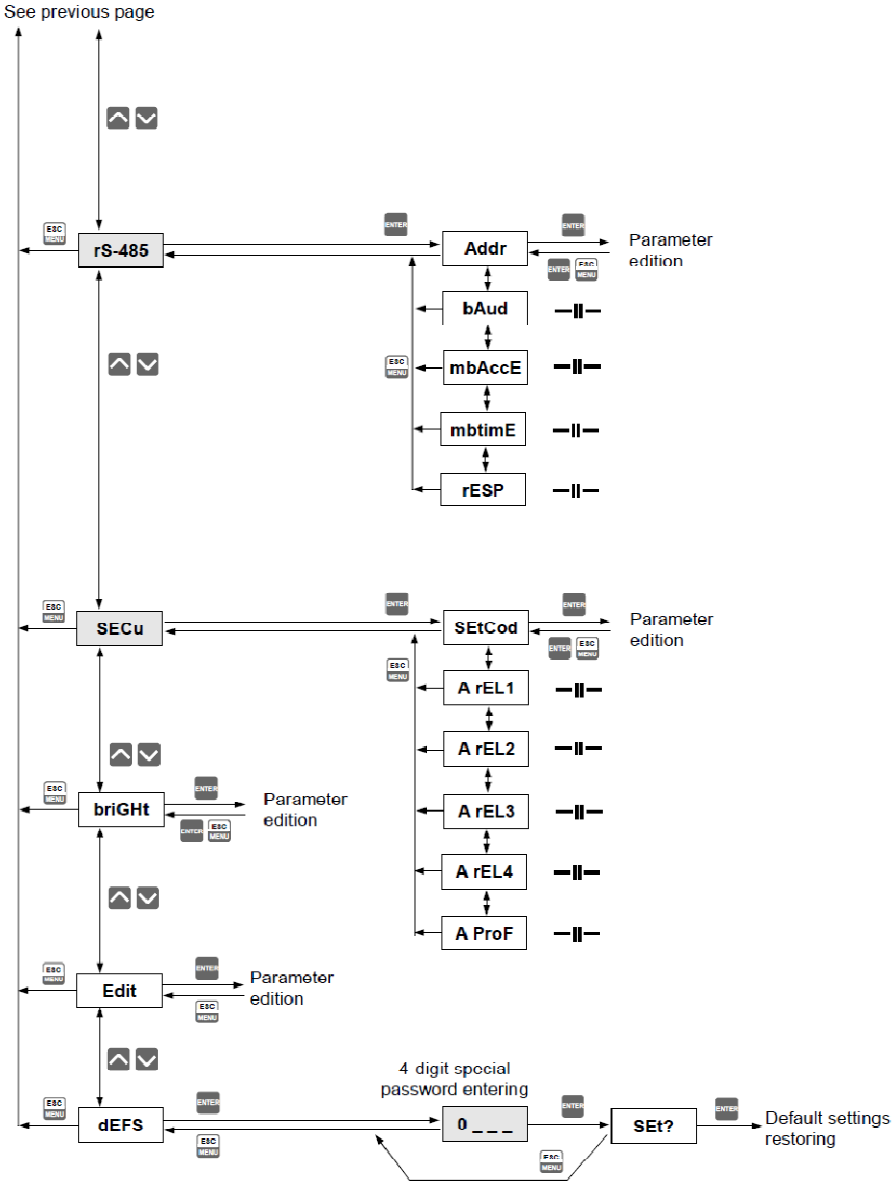

8. EXAMPLES OF PRESCALER PARAMETERS CALCULATION

Problem: to measure length of the line with assumed precision.
Essential data: - number of pulses per revolution given by sensor
- circumference of measurement circle
- assumed measurement unit and resolution (mm, cm, dm, m)

Example 1

Data:
- circumference of measurement circle: **25 cm**
- number of pulses: **100 pulses/revolution**
- unit **cm**, resolution **1 cm**

Settings:
mul = "25"
div = "100"
point = "0."

Problem 2: The chain should be marked every 10 m, and cutted in segments of settable length, with given precision.

To realize this function the counter should be switched to marker mode "Func1" = "**mAr**". The circuit needs at least 2 relays. Relay R2 will be drive the cutter, and R1 the marking divide. Settings of the markers is realized using menu "**rELAY1**" ("**SEtP 1**"), and the cutter using "**rELAY2**" ("**SEtP 2**") - see chapter: The "**marker**" mode.

User should first collect following data:

- pulses per revolution given by the sensor
- circumference of the measuring wheel
- define smallest unit of the measurement (mm, cm, dm, m)
- define distance between markers, and length of cut segments

Example 3

Data:
- circumference of measurement wheel: **25 cm**
- number of pulses: **100 pulses/revolution**
- unit **m**, resolution **0.1 cm**
- marker every **1 m**, cut segments of **100 m**

Settings:
mul = "25"
div = "1000"
point = "0.0"
SEtP 1 = 1.0
SEtP 2 = 100.0

Example 2

Data:
- circumference of measurement circle: **50 cm**
- number of pulses: **100 pulses/revolution**
- unit **dm**, resolution **0.1 dm**

Settings:
mul = "25"
div = "100"
point = "0.0"

Example 4

Data:
- circumference of measurement wheel: **50 cm**
- number of pulses: **1000 pulses/revolution**
- unit **dm**, resolution **0.01 dm**
- marker every **1 dm**, cut segments of **10 m = 100 dm**

Settings:
mul = "5"
div = "10"
point = "0.00"
SEtP 1 = 1.00
SEtP 2 = 100.00

9. THE MODBUS PROTOCOL HANDLING

Transmission parameters: 1 start bit, 8 data bits, 1 or 2 stop bit (2 bits are send, 1 and 2 bits are accepted when receive), no parity control
 Baud rate: selectable from: 1200 to 115200 bits/sec
 Transmission protocol: MODBUS RTU compatible

The device parameters and display value are available via RS-485 interface, as HOLDING-type registers (numeric values are given in U2 code) of Modbus RTU protocol. The registers (or groups of the registers) can be read by 03h function, and wrote by 06h (single registers) or 10h (group of the registers) accordingly to Modbus RTU specification. Maximum group size for 03h and 10h functions cannot exceeds 16 registers (for single frame).



The device interprets the broadcast messages, but then do not sends the answers.

9.1. LIST OF REGISTERS

Register	Write	Range	Register description
01h ¹	No	depend on value type	Display value - first (higher) word.
02h ¹	No		Display value - second word.
03h ¹	No		Display value - third (lower) word.
04h	Yes	see descr.	High byte - type of the displayed value (reg. 01h, 02h, 03h): 00h or 01h - main counter result 02h or 03h - cycle counter / result or global distance in "marker" mode 04h - more significant half of the totalizer (is displayed) 05h - less significant half of the totalizer (is displayed) Low byte - the status of the displayed value: 00h - normal , 01h - underflow of cycles counter in "marker" mode 02h - overflow of cycles counter in "marker" mode 04h - cycle counter underflow 08h - cycle counter overflow 10h - totalizer underflow 20h - totalizer overflow 40h - main counter underflow 80h - main counter overflow
05h ²	Yes	see descr.	Main counter value - first (higher) word
06h ²	Yes	see descr.	Main counter value - second word.
07h ²	Yes	see descr.	Main counter value - third (lower) word.
08h ²	Yes	see descr.	Cycle counter value - first (higher) word
09h ²	Yes	see descr.	Cycle counter value - second (lower) word.
0Ah ²	Yes	see descr.	Totalizer value - first (higher) word
0Bh ²	Yes	see descr.	Totalizer value - second word.
0Ch ²	Yes	see descr.	Totalizer value - third word.

Register	Write	Range	Register description
0Dh ²	Yes	see descr.	Totalizer value - fourth (lower) word.
0Eh	Yes	see descr.	State of the relays (binary format) (1 - on, 0 - off): 00000000 0000dcba a - relay R1; b - relay R2; c - relay R3; d - relay R4; If written, only a, b, c, d bits are important (others are ignored) these bits allows user to control the relays via RS-485 interface
0Fh	No	see descr.	The state of relays task in binary format 1 – relay was activated (or still is), 0 – relay wasn't activated, and will be as soon as result reaches the threshold. Format: 0000 0000 0000 dcba a - relay R1; b - relay R2; c - relay R3; d - relay R4; This register is very important while relays are activated on defined period of time. It allows the counter to know if relay was activated or not
10h	Yes	0÷8	“ In 1 ” parameter in “ Pr In ” menu (programmable input 1 function): 0 - “ diSAbl ” mode; 1 - “ rES m ” mode; 2 - “ rES c ” mode; 3 - “ rES mc ” mode; 4 - “ rES t ” mode; 5 - “ rES mt ” mode; 6 - “ rES ct ” mode; 7 - “ rES ALL ” mode; 8 - “ dirEct ” mode
11h	Yes	0÷8	“ In 1 ” parameter in “ Pr In ” menu (programmable input 2 function): 0 - “ diSAbl ” mode; 1 - “ rES m ” mode; 2 - “ rES c ” mode; 3 - “ rES mc ” mode; 4 - “ rES t ” mode; 5 - “ rES mt ” mode; 6 - “ rES ct ” mode; 7 - “ rES ALL ” mode; 8 - “ dirEct ” mode
12h	Yes	0÷3	“ rES m ” parameter in “ rESEtS ” menu (main counter reset source): 0 - “ ALL ”, 1 - “ EL ”, reset with { REST } input and RS-485 interface 2 - “ mAn ”, reset with [RESET] button and RS-485 interface 3 - “ none ”, reset with RS-485 interface only
13h	Yes	0÷3	“ rES c ” parameter in “ rESEtS ” menu (cycles counter reset source): 0 - “ ALL ”, 1 - “ EL ”, reset with { REST } input and RS-485 interface 2 - “ mAn ”, reset with [RESET] button and RS-485 interface 3 - “ none ”, reset with RS-485 interface only
14h	Yes	0÷3	“ rES t ” parameter in “ rESEtS ” menu (totalizer reset source): 0 - “ ALL ”, 1 - “ EL ”, reset with { REST } input and RS-485 interface 2 - “ mAn ”, reset with [RESET] button and RS-485 interface 3 - “ none ”, reset with RS-485 interface only
15h	Yes	0÷1	“ ArESEt ” parameter in “ rESEtS ” menu (main counter or cycle counter autoreset): 0 - “ oFF ” 1 - “ on ”
16h	Yes	0÷1	“ FuncT ” parameter in “ mAin ” menu (relay output activation mode): 0 - “ Std ” mode; 1 - “ mAr ” mode
17h	Yes	0÷1	“ dir ” parameter in “ mAin ” menu (main counter direction): 0 - “ norm ” mode 1 - “ rev ” mode

Register	Write	Range	Register description
18h	Yes	0÷3	“ ProFIL ” parameter in “ PrESCA ” menu (current set of the factors): 0 - profile no1... 3 - profile no4
Current profile parameters (read only)			
19h	No	see descr.	“ mul ” in “ PrESCA ” menu (main counter multiplier, high word);
1Ah	No	see descr.	“ mul ” in “ PrESCA ” menu (main counter multiplier, low word); Cumulative value of registers 19h and 1Ah: from -99999 to 999999
1Bh	No	see descr.	“ div ” parameter in “ PrESCA ” menu (input divider, high word);
1Ch	No	see descr.	“ div ” parameter in “ PrESCA ” menu (input divider, low word); Cumulative value of registers 1Bh and 1Ch: from 1 to 999999
1Dh	No	see descr.	“ oFFSet ” parameter in “ PrESCA ” menu (high word)
1Eh	No	see descr.	“ oFFSet ” parameter in “ PrESCA ” menu (low word) Cumulative value of registers 1Dh and 1Eh: from -99999 to 999999
1Fh	No	0÷5	“ Point ” parameter in “ PrESCA ” menu (decimal point position) 0 - “ 0 ”; 1 - “ 0.0 ”; 2 - “ 0.00 ”; 3 - “ 0.000 ”; 4 - “ 0.0000 ”; 5 - “ 0.00000 ”
20h ³	Yes	0 ÷ 199	Device address
21h	No	20D0h	Device identification code (ID)
22h ⁴	Yes	0÷7	“ bAud ” parameter in “ rS-485 ” menu (baud rate); 0 - 1200 baud; 1 - 2400 baud; 2 - 4800 baud; 3 - 9600 baud; 4 - 19200 baud; 5 - 38400 baud; 6 - 57600 baud; 7 - 115200 baud
23h ⁵	Yes	0÷1	“ mbAccE ” parameter in “ rS-485 ” menu (permission to write registers via RS-485 interface); 0 - write denied ; 1 - write allowed
24h	Yes	see descr.	Parameters of “ SECU ” menu (binary format (0 – “ oFF ”, 1 – “ on ”): bit 0 - “ A rEL1 ” parameter; bit 1 - “ A rEL2 ” parameter bit 2 - “ A rEL3 ” parameter; bit 3 - “ A rEL4 ” parameter; bit 4 - “ A ProF ” parameter
25h	Yes	0÷5	“ rESP ” parameter in “ rS-485 ” menu (additional response delay); 0 - no additional delay; 1 - “ 10c ” option; 2 – “ 20c ” option; 3 - “ 50c ” option; 4 – “ 100c ” option; 5 – “ 200c ” option;
27h	Yes	0÷99	“ mbtime ” parameter in “ rS-485 ” menu (maximum delay between received frames); 0 - no delay checking; 1 ÷ 99 - maximum delay expressed in seconds
2Dh	Yes	1÷8	“ brighT ” parameter (display brightness); 1 - the lowest brightness; 8 - the highest brightness
2Fh	Yes	0÷1	“ Edit ” parameter (numerical parameters edit mode); 0 - „ dig ” mode; 1 - “ SLid ” mode
30h ⁶	Yes	see descr.	“ SEtP 1 ” parameter in “ rELAy 1 ” menu (high word).
31h ⁶	Yes	see descr.	“ SEtP 1 ” parameter in “ rELAy 1 ” menu (low word). Cumulative value of registers 30h and 31h: from -99999 to 999999
32h	Yes	0÷3	“ modE 1 ” parameter in “ rELAy 1 ” menu: 0 - “ noAct ” mode; 1 - “ on ” mode; 2 - “ oFF ” mode; 3 - “ modbuS ” mode

Register	Write	Range	Register description
33h	Yes	0÷999	“ timE 1 ” parameter in “ rELAY 1 ” menu (the time period of the relay active state), expressed in tenth of seconds or tenth of minutes (depending on “ unit ” parameter);
34h	Yes	0÷1	“ unit 1 ” parameter in “ rELAY 1 ” menu: 0 - “ SEC ” option; 1 - “ min ” option
Registers from 38h to 3Ch			Parameters in “ rELAY 2 ” menu, registers description like for “ rELAY 1 ” menu (see registers 30h to 34h)
40h ⁶	Yes	see descr.	“ SEtP 3 ” parameter in “ rELAY 3 ” menu (high word).
41h ⁶	Yes	see descr.	“ SEtP 3 ” parameter in “ rELAY 3 ” menu (low word). Cumulative value of registers 40h and 41h: from -99999 to 999999
42h	Yes	0÷3	“ modE 3 ” parameter in “ rELAY 3 ” menu: 0 - “ noAct ” mode; 1 - “ on ” mode; 2 - “ oFF ” mode; 3 - “ modbuS ” mode
43h	Yes	0÷999	“ timE 3 ” parameter in “ rELAY 3 ” menu (the time period of the relay active state), expressed in tenth of seconds or tenth of minutes (depending on “ unit ” parameter);
44h	Yes	0÷1	“ unit 3 ” parameter in “ rELAY 3 ” menu: 0 - “ SEC ” option; 1 - “ min ” option
45h	Yes	0÷1	“ Srct 3 ” parameter in “ rELAY 3 ” menu: 0 - “ mAin ” option; 1 - “ CyCLES ” option
Registers from 48h to 4Dh			Parameters in “ rELAY 4 ” menu, registers description like for “ rELAY 3 ” menu (see registers 40h to 45h)
50h	No	see descr.	The main counter's result - high word
51h	No	see descr.	The main counter's result - low word
52h	No	see descr.	The cycles counter - high word
53h	No	see descr.	The cycles counter - low word
54h	No	see descr.	The totalizer - most significant word
55h	No	see descr.	The totalizer - medium significant word
56h	No	see descr.	The totalizer - least significant word
57h	No	see descr.	The cycles counter in “marker” mode - high word
58h	No	see descr.	The cycles counter in “marker” mode - low word
Current profile selection			
70h	Yes	0÷4	“ ProFiL ” parameter in “ PrESCA ” menu (current set of the factors): 0 - profile no1...4 - profile no5
Current profile settings			
71h	Yes	see descr.	“ muL ” in “ PrESCA ” menu (main counter multiplier, high word);
72h	Yes	see descr.	“ muL ” in “ PrESCA ” menu (main counter multiplier, low word); Cumulative value of registers 71h and 72h: from -99999 to 999999
73h	Yes	see descr.	“ div ” parameter in “ PrESCA ” menu (input divider, high word);

Register	Write	Range	Register description
74h	Yes	see descr.	“ div ” parameter in “ PrESCA ” menu (input divider, low word); Cumulative value of registers 73h and 74h: from 1 to 999999
75h	Yes	see descr.	“ oFFSET ” parameter in “ PrESCA ” menu (high word)
76h	Yes	see descr.	“ oFFSET ” parameter in “ PrESCA ” menu (low word) Cumulative value of registers 75h and 76h: from -99999 to 999999
77h	Yes	0÷5	“ Point ” parameter in “ PrESCA ” menu (decimal point position) 0 - “ 0 ”; 1 - “ 0.0 ”; 2 - “ 0.00 ”; 3 - “ 0.000 ”; 4 - “ 0.0000 ”; 5 - “ 0.00000 ”
Profile no 1 settings			
79h	Yes	see descr.	“ mul ” in “ PrESCA ” menu (main counter multiplier, high word);
7Ah	Yes	see descr.	“ mul ” in “ PrESCA ” menu (main counter multiplier, low word); Cumulative value of registers 79h and 7Ah: from -99999 to 999999
7Bh	Yes	see descr.	“ div ” parameter in “ PrESCA ” menu (input divider, high word);
7Ch	Yes	see descr.	“ div ” parameter in “ PrESCA ” menu (input divider, low word); Cumulative value of registers 7Bh and 7Ch: from 1 to 999999
7Dh	Yes	see descr.	“ oFFSET ” parameter in “ PrESCA ” menu (high word)
7Eh	Yes	see descr.	“ oFFSET ” parameter in “ PrESCA ” menu (low word) Cumulative value of registers 7Dh and 7Eh: from -99999 to 999999
7Fh	Yes	0÷5	“ Point ” parameter in “ PrESCA ” menu (decimal point position) 0 - “ 0 ”; 1 - “ 0.0 ”; 2 - “ 0.00 ”; 3 - “ 0.000 ”; 4 - “ 0.0000 ”; 5 - “ 0.00000 ”
Profile no 2 settings			
Registers from 81h to 87h	Profile no 2 parameters, registers description like for profile no 1 (see registers 78h to 7Eh)		
Profile no 3 settings			
Registers from 89h to 8Fh	Profile no 3 parameters, registers description like for profile no 1 (see registers 78h to 7Eh)		
Profile no 4 settings			
Registers from 91h to 97h	Profile no 4 parameters, registers description like for profile no 1 (see registers 78h to 7Eh)		

- 1 - if overflow or underflow occurs (“**-Hi-**” or “**-Lo-**”), read of registers 01h, 02h and 03h (single registers) it returns recalculated number of pulses (while the overload of display quantity is very big this value can be erroneous). Register 03h returns according error code.
- 2 - Preset of 0000h to these registers (04h÷ 0Dh) causes by zeroing of main counter and precounter content
- 3 - after writing to register no 20h the device responds with an “old” address in the message.
- 4 - after writing to register no 22h the device responds with the new baud rate.
- 5 - the value of the “**mbAc**” parameter is also connected to write to this register, so it is possible to block a writes, but impossible to unblock writes via RS-485 interface, The unblocking of the writes is possible from menu level only.
- 6 - numbers written to holding registers of relays thresholds are interrelated with each other auto-correction. For example. Preset to reg. 31h (threshold lower word) of value, which together with content of register 30h (threshold higher word) gets value from behind of allowable range, will fails. Over more preset to reg 30h of value which together with content of register 31h gets value from behind of allowable range, will modify the content of register 31h, in that way to it's value together with register 30h be located in allowable range. If appropriate modification is impossible, write fails. It is recommended to write threshold values in presented manner: first preset of threshold higher word, and next threshold lower word. Similarly storing thresholds registers of another relays is realised with each other correction.

9.2. TRANSMISSION ERRORS DESCRIPTION

If an error occurs while write or read of single register, then the device sends an error code according to Modbus RTU specifications.

Error codes:

- 01h** - illegal function (only functions 03h, 06h and 10h are available)
- 02h** - illegal register address
- 03h** - illegal data value
- 08h** - no write permission (see: "mbAccE" parameter)

9.3. EXAMPLES OF QUERY/ANSWER FRAMES

Examples apply for device with address 1. All values are represent hexadecimal.

Field description:

- ADDR** Device address on modbus network
- FUNC** Function code
- REG H,L** Starting address (address of first register to read/write, Hi and Lo byte)
- COUNT H,L** No. of registers to read/write (Hi and Lo byte)
- BYTE C** Data byte count in answer frame
- DATA H,L** Data byte (Hi and Lo byte)
- CRC L,H** CRC error check (Hi and Lo byte)

1. Read of device ID code

ADDR	FUNC	REG H,L		COUNT H,L		CRC L,H	
01	03	00	21	00	01	D4	00

The answer:

ADDR	FUNC	BYTE C	DATA H,L		CRC L,H	
01	03	02	20	D0	A0	18

DATA - identification code (20D0h)

2. Change of the device address from 1 to 2 (write to reg. 20h)

ADDR	FUNC	REG H,L		DATA H,L		CRC L,H	
01	06	00	20	00	02	09	C1

DATA H - 0

DATA L - new device address (2)

The answer (the same as the message):

ADDR	FUNC	REG H,L		DATA H,L		CRC L,H	
01	06	00	20	00	02	09	C1

3. Change of baud rate of all devices connected to the net (BROADCAST message).

ADDR	FUNC	REG H,L		COUNT H,L		CRC L,H	
00	06	00	22	00	04	29	D2

DATA H - 0

DATA L - 4, new baud rate 19200 baud



Device do not reply to BROADCAST-type messages.

4. Read of the displayed value (higher word):

ADDR	FUNC	REG H,L		COUNT H,L		CRC L,H	
01	03	00	01	00	01	D5	CA

Response, while normal operation (no errors):

ADDR	FUNC	BYTE C	DATA H,L		CRC L,H	
01	03	02	00	00	B8	4C

DATA H, L - higher word of displayed value = 00

5. Read of the full displayed value (registers 01h, 02h i 03h)

ADDR	FUNC	REG H,L		COUNT H,L		CRC L,H	
01	03	00	01	00	03	54	0B

Response, while normal operation (no errors):

ADDR	FUNC	BYTE C	DATA H1,L1		DATA H2,L2		DATA H3,L3		CRC L,H	
01	03	06	00	00	00	00	00	57	60	8B

DATA - 00000057h = 87, displayed value = 87

6. Change of mode of programmable input IN2, “In 2”=“rES m”

ADDR	FUNC	REG H,L		DATA H,L		CRC L,H	
01	06	00	11	00	01	18	0F

The answer (the same as the message):

ADDR	FUNC	REG H,L		DATA H,L		CRC L,H	
01	06	00	11	00	01	18	0F

7. Try to write illegal data value into baud rate register

ADDR	FUNC	REG H,L		DATA H,L		CRC L,H	
01	06	00	22	00	09	E9	C6

DATA L = 9 - value exceeds allowable range (0 ÷ 7)

The answer (exception code 03h - illegal data value):

ADDR	FUNC	ERR	CRC L,H	
01	86	03	02	61



There is no full implementation of the Modbus Protocol in the device. The functions presented above are available only.

10. DEFAULT AND USER'S SETTINGS LIST

Parameter	Description	Default value	User's value	Desc. page
Parameters of relay R1 operation ("rELAY1" menu)				
SEtP 1	Relay threshold	4000		27
modE 1	Operation mode of relay	on		27
timE 1	The time period of the relay <i>active state</i>	1.0		27
unit 1	Unit of " timE " parameter	SEC		27
Parameters of relay R2 operation ("rELAY2" menu)				
SEtP 2	Relay threshold	3000		27
modE 2	Operation mode of relay	on		27
timE 2	The time period of the relay <i>active state</i>	1.0		27
unit 2	Unit of " timE " parameter	SEC		27
Parameters of relay R3 operation ("rELAY3" menu)				
Src3	The source of relay 3 controlling	main		26
SEtP 3	Relay threshold	2000		27
modE 3	Operation mode of relay	on		27
timE 3	The time period of the relay <i>active state</i>	1.0		27
unit 3	Unit of " timE " parameter	SEC		27
Parameters of relay R4 operation ("rELAY4" menu)				
Src4	The source of relay 4 controlling	main		30
SEtP 4	Relay threshold	1000		27
modE 4	Operation mode of relay	on		27
timE 4	The time period of the relay <i>active state</i>	1.0		27
unit 4	Unit of " timE " parameter	SEC		27
Settings of main counter ("mAin" menu)				
Funct	The operation mode of the counter	Std		27
dir	Main counter direction	norm		28
Methods and sources of counters clearing ("rESEtS" menu)				
ArESEt	<i>Autoreset</i> function	on		28
rES m	Main counter reset source	ALL		28
rES c	Cycles counter reset source	ALL		29
rES t	Totalizer reset source	ALL		29
Settings of programmable input ("Pr In" menu)				
In 1	Programmable input IN1 function	diSAbL		30

<i>Parameter</i>	<i>Description</i>	<i>Default value</i>	<i>User's value</i>	<i>Desc. page</i>
In 2	Programmable input IN2 function	diSAbL		30
Prescaler settings ("PrESCA" menu)				
ProFiL	Current profile selection	0		31
muL	multiplier	1		31
div	divider	1		31
Offset	Offset - constant value added to the result to move the zero point of the current scale	0		31
Point	Decimal point position	0.0		31
RS 485 interface configuration ("rS-485" menu)				
Addr	Device address	1		31
bAud	Baud rate	9600		31
mbAccE	Permission to changes of configuration registers	on		31
mbtimE	Maximum delay between received messages	0		32
rESP	Additional delay of answer transmission	Std		32
Settings of access to the configuration parameters ("SECU" menu)				
A rEL1	Permission to changes of relay R1 threshold without of the user password knowledge	oFF		33
A rEL2	Permission to changes of relay R2 threshold without of the user password knowledge	oFF		33
A rEL3	Permission to changes of relay R3 threshold without of the user password knowledge	oFF		33
A rEL4	Permission to changes of relay R4 threshold without of the user password knowledge	oFF		33
A ProF	Permission to change profile without of the user password knowledge	oFF		33
Display parameters				
briGHt	Display brightness	bri6		34
Configuration of numerical parameters edition				
Edit	Numerical parameters edit mode	dig		34



BD|Sensors GmbH
BD-Sensors-Straße 1
95199 Thierstein, Germany

Telefon +49 (0) 9235 / 9811 - 2099
Telefax +49 (0) 9235 / 9811 - 860

e-mail: info@bdsimex.de
www.bdsimex.de